



Bulletin MSG11-3236-M1/UK

Installation Manual Series PCD 00A-400

Design ≥ 40

Electronics for Proportional Pressure/ Throttle Valves



Parker Hannifin
Manufacturing Germany GmbH & Co. KG
Industrial Systems Division Europe
Gutenbergstr. 38
41564 Kaarst, Germany
E-mail: isde.kaarst.support@support.parker.com
Copyright © 2022, Parker Hannifin Corp.



WARNING — USER RESPONSIBILITY

FAILURE OR IMPROPER SELECTION OR IMPROPER USE OF THE PRODUCTS DESCRIBED HEREIN OR RELATED ITEMS CAN CAUSE DEATH, PERSONAL INJURY AND PROPERTY DAMAGE.

This document and other information from Parker-Hannifin Corporation, its subsidiaries and authorized distributors provide product or system options for further investigation by users having technical expertise.

The user, through its own analysis and testing, is solely responsible for making the final selection of the system and components and assuring that all performance, endurance, maintenance, safety and warning requirements of the application are met. The user must analyze all aspects of the application, follow applicable industry standards, and follow the information concerning the product in the current product catalog and in any other materials provided from Parker or its subsidiaries or authorized distributors.

To the extent that Parker or its subsidiaries or authorized distributors provide component or system options based upon data or specifications provided by the user, the user is responsible for determining that such data and specifications are suitable and sufficient for all applications and reasonably foreseeable uses of the components or systems.

Installation Manual

Parker electronic modules series PCD00A-400 for rail mounting are compact, easy to install and provide time-saving wiring by disconnectable terminals. The digital design of the circuit results in good accuracy and optimal adaption for proportional pressure/flow control valves by a comfortable interface program.

Features

The described electronic unit combines all necessary functions for the optimal operation of two proportional pressure/flow control valves (series R*V, RE*E*W, RE06M*W, DUR, PRPM, VBY, VMY, TDA, TEA). The most important features are:

- Digital circuit design
- Two independent operable amplifiers
- Four parameterizable preset recall channels
- Constant current control
- Two input stages 0...10 V
- Status output
- Two up/down ramp functions
- Enable input for solenoid driver
- Status indicator
- Parametering by USB interface

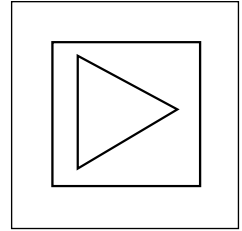
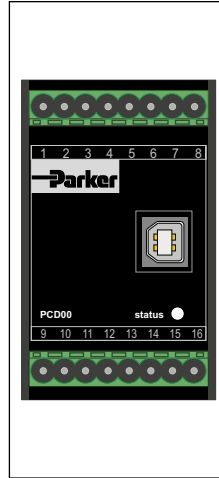

- Connection by disconnectable terminals
- Compatible to the relevant European EMC standards
- Comfortable PC user software, free of charge: www.parker.com/isde see "Support", or directly at www.parker.com/propxd.



Diagram

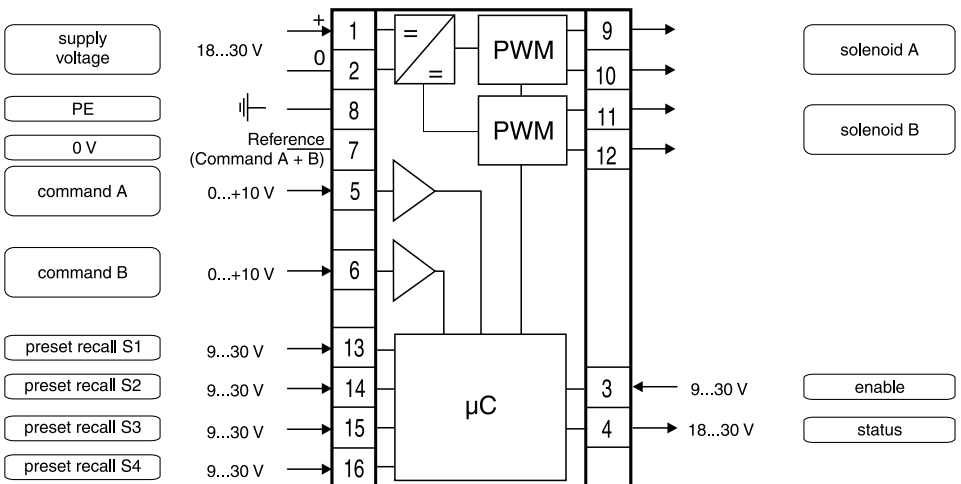

PCD00A 3236-M1 UK.indd CM 12.05.22



Installation Manual

Technical Data

General	
Model	Module package for snap-on mounting on EN 50022 rail
Package material	Polycarbonate
Inflammability class	V0 acc. UL 94
Installation position	Any
Ambient temperature range [°C]	-20...+60
Protection class	NEMA 1/IP20 acc. EN 60529
Weight [g]	160
Electrical	
Duty ratio [%]	100
Supply voltage [VDC]	18...30, ripple < 5 % eff., surge free *)
Switch-on current typ. [A]	22 for 0.2 mS
Current consumption max. [A]	5.0
Pre-fusing [A]	6.3 A medium lag
Command signal [V]	0...+10, ripple < 0.01 % eff., surge free, Ri = 150 kOhm
Input signal resolution [%]	0,025
Differential input voltage max. [V]	30 for terminals 5 und 6 against PE (terminal 8)
Enable signal [V]	0...4.0: Off / 9.0...30: On / Ri = 30 kOhm
Channel recall signal [V]	0...4.0: Off / 9.0...30: On / Ri = 30 kOhm
Status signal [V]	0...0.5: Off / Us: On / rated max. 15 mA
Adjustment ranges	Min [%] 0...50 Max [%] 50...100 Ramp [s] 0...32.5 Current [A] 0.8/1.3/1.8/2.7/3.5
Interface	USB type B
EMC	EN IEC 61000-6-2, EN IEC 61000-6-4
Connection	Screw terminals 0.2...2.5 mm ² , disconnectable
Cable specification [AWG]	16 overall braid shield for supply voltage and solenoids 20 overall braid shield for sensor and signal
Cable length [m]	50

*) If solenoids with a nominal voltage of 24 V are connected, the supply voltage has to be raised to 29 V.

Ordering Code

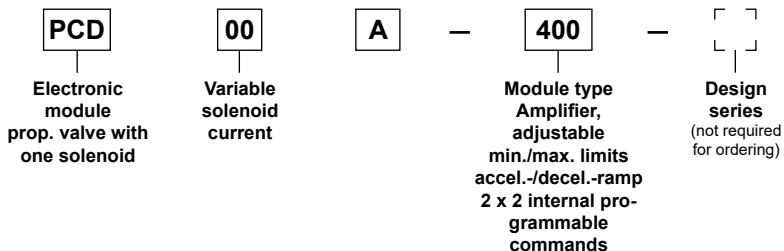

Installation Manual

Signal Flow Diagram A

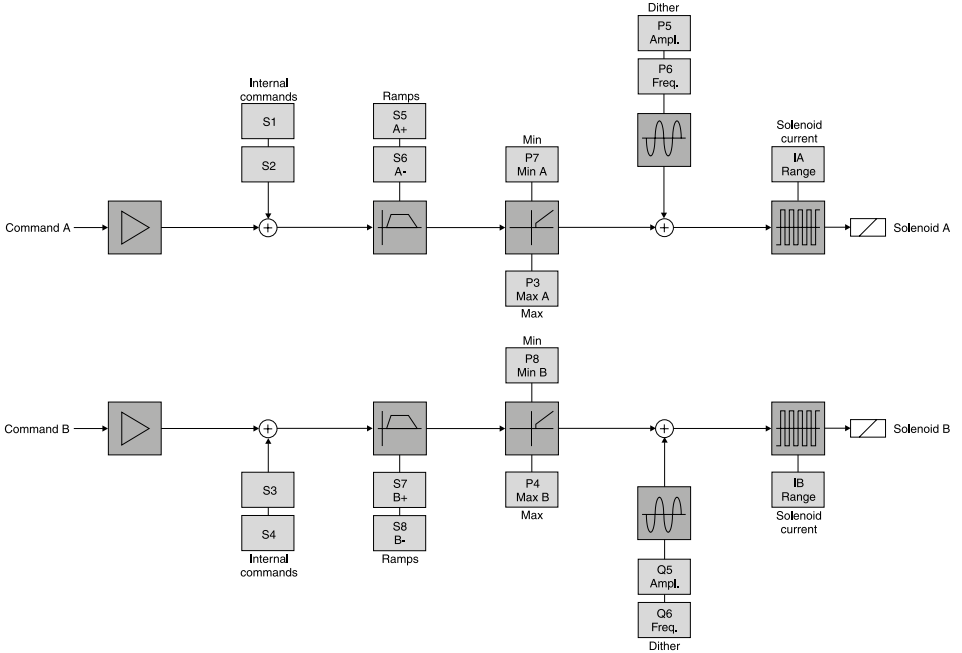

Commands

Additionally to the external analogue command inputs (Pins 5-7 and 6-7), the PCD00A-400-electronic includes, for each channel, two internal programmable command values S1 to S4, which can be activated by the switching inputs (Pins 13, 14, 15, 16). S1 (Pin 13) has a higher priority than

S2 (Pin 14) and S3 (Pin 15) has a higher priority than S4 (Pin 16).

If only one amplifier channel is used, it is possible to switch all four internal commands to this channel by setting parameter N=1.

Installation Manual

Ramp-function / Min-Max-function

The PCD00A-400-electronic includes two internal programmable ramps for each channel. Addition-

ally a current step may be programmed (Min) and / or the current may be limited (Max) for each

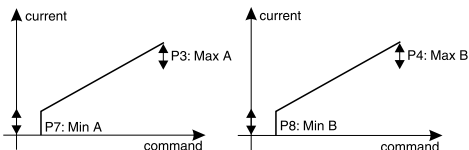
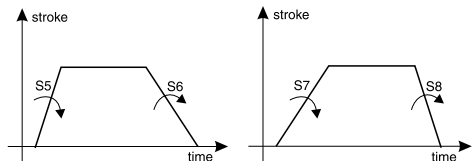

Nominal current adjustment

The nominal current can be adjusted by one parameter separately for each channel (Pin 9, 10, or 11, 12). The default nominal current is 800 mA.

Parameterization

All of the following parameter values can be changed via a USB connection (type B) using the user software.



The connected valves may not operated before loading an appropriate parameter set from the PC into the module electronics.

Example of parameter chart

Parameter	Range	Default value	Unit	Function
P3	50.0...100.0	100.0	%	max. current A-channel
P4	50.0...100.0	100.0	%	max. current B-channel
P5	0.0...10.0	0.0	%	Dither amplitude A-channel
P6	0...300	0	Hz	Dither frequency A-channel
P7	0.0...50.0	0.0	%	Min. current A-channel
P8	0.0...50.0	0.0	%	Min. current B-channel
Q5	0.0...10.0	0.0	%	Dither amplitude B-channel
Q6	0...300	0	Hz	Dither frequency B-channel
S1	0.0...+100.0	0.0	%	Internal command 1
S2	0.0...+100.0	0.0	%	Internal command 2
S3	0.0...+100.0	0.0	%	Internal command 3
S4	0.0...+100.0	0.0	%	Internal command 4
S5	0...32500	0	ms	Ramp UP A-channel
S6	0...32500	0	ms	Ramp DOWN A-channel
S7	0...32500	0	ms	Ramp UP B-channel
S8	0...32500	0	ms	Ramp DOWN B-channel
IA	0, 1, 2, 3, 4	-	-	Nominal current A-channel, 0=0.8 A; 1=3.5 A; 2=2.7 A; 3=1.8 A; 4=1.3A
IB	0, 1, 2, 3, 4	-	-	Nominal current B-channel, 0=0.8 A; 1=3.5 A; 2=2.7 A; 3=1.8 A; 4=1.3 A
n	1, 2	2	-	Allocation of internal command signals

All parameters are saved in an EEPROM and become active directly after supply voltage is switched on.

PCD00A 3236-M1 UK.indd CM 12.05.22

Connection Examples

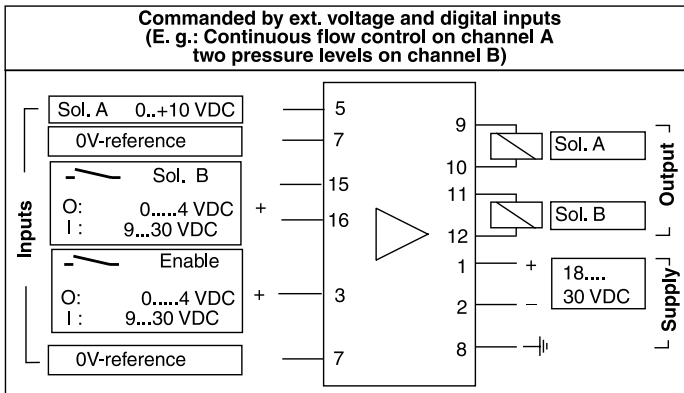
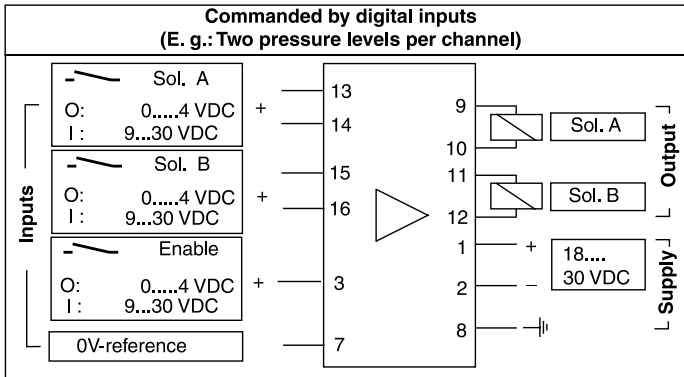
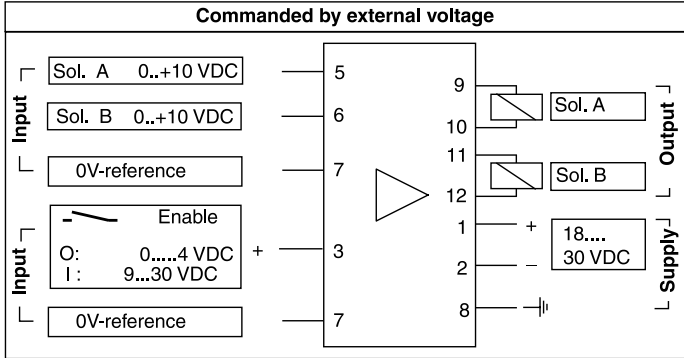

Certainly combinations and / or modifications of these examples are possible. The priority of the digital inputs over the analogue inputs has to be kept in mind! Via parameter N=1 all four digital inputs may be dedicated to channel A.

Installation Manual

Pinning

Pin	Description	Pin	Description
1	+ supply 18...30 VDC	9	channel A
2	GND supply 0 VDC	10	channel A
3	Enable input 9...30 VDC	11	channel B
4	Status output 0 VDC / 18...30 VDC	12	channel B
5	Cmd. A-channel 0...+10 VDC	13	int. command 1 0 VDC / 18...30 VDC
6	Cmd. B-channel 0...+10 VDC1	4	int. command 2 0 VDC / 18...30 VDC
7	GND cmds./dig.IO 0 VDC	15	int. command 3 0 VDC / 18...30 VDC
8	PE Earth	16	int. command 4 0 VDC / 18...30 VDC

Enable input and status output

The enable input activates (9...30 VDC) the power amplifiers or deactivates them (0 VDC). The status output delivers 18...30 VDC during normal operation. It switches to 0 VDC in case of an error.

Standard Parameters

Valve	Solenoid	Nominal Current		Dither	
		I_{\max} A-side (IA)	I_{\max} B-side (IB)	Amplitude (P5)	Frequency (P6)
TDA	L	1.3 A (4) a. P3=80.7	1.3 A (4)	1.6	21
	M	2.7 A (2)	2.7 A (2)	0.8	21
DSA	L	1.3 A (4)	1.3 A (4)	1.6	88
VBY/VMY	L	0.8 A (0)	0.8 A (0)	2.4	88
	M	2.7 A (2)	2.7 A (2)	2.4	88

Please obey supply voltage (see technical data sheets).

Dimensions

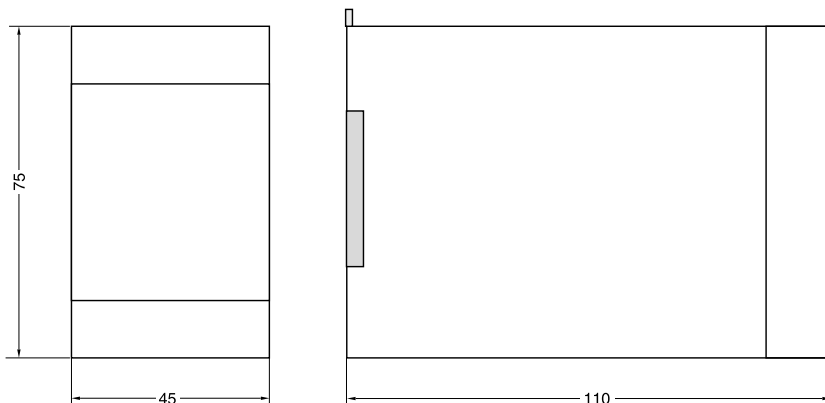

Installation guide to electronic modules to provision of electromagnetic compatibility

Power Supply

The utilized power supply has to comply with the EMC-standards (CE-sign, certificate of conformity).

Relais and solenoids operating from the same supply circuit as the valve electronics have to be fitted by surge protection elements.

Wiring Cable

The wires between the installation site of the module and the peripheral units, as power supply, valve solenoids, position transducer, command signal source have to be shielded. The following wire sizes must be reached: power supply AWG 16, other connections AWG 20. The capacity should not exceed a value of approx. 130 pF/m (wire/wire). The maximum cable length is 50 m. No power current lines may be placed within the wired shielded cables to the electronic module. The cable shield has to be connected to ground at both ends (see also chapter "Grounding"). Please be aware of ground loops.

Installation

The module has to be mounted within a conductive, shielded enclosure. Usable is i.e. an EMC-approved control cabinet. A perfect grounding of the enclosure is mandatory (see also chapter "Grounding").

Grounding

The mounting plate of the valve has to be connected to the grounded metal machine frame. The cable shields must be tied to ground at the control cabinet. A low-ohmic potential compensation wire has to be provided between the control cabinet and the machine frame (cable wire >AWG 7 cross section) to prevent ground loops.

